

Cobra V-12/20

diode pumped Nd:Vanadate
laser marking systems



- high speed fine detail marking
- spot size does not vary with laser power
- marks coated materials without damaging sensitive substrates
- diodes guaranteed for 15,000 hours/2years
- compact light weight construction
- air cooled
- single phase power
- user friendly Windows™ software for optimum marking performance
- available as modules for production line integration or with choice of workstation for turnkey solution



Cobra V-12/20

diode pumped Nd:Vanadate
laser marking systems

marking area parameters

flat field lens focal length	maximum square marking field	maximum marking diameter	working distance
100 mm	60 mm	85 mm	106 mm
163 mm	100 mm	140 mm	184 mm
254 mm	160 mm	220 mm	323 mm
410 mm	250 mm	350 mm	512 mm

dimensions

	Height (ins) (mm)	Length (ins) (mm)	Width (ins) (mm)	Weight (lbs) (kg)
Laser Enclosure	7 177	24 620	6 165	31 14
Control Unit	18 458	21 528	23 593	128 58

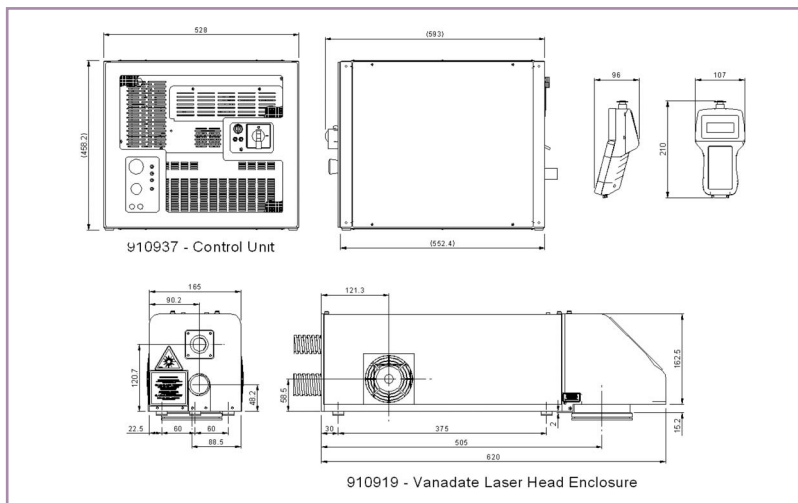

laser specification

Laser Type – Nd:Vanadate disk
Wavelength – 1064nm
Pulse frequency – 0.1 – 100kHz
Max marking speed – 10,000mm.s⁻¹
Operating mode – Q-switched
Operating temperature – up to 40°C non condensing
Construction – Dust sealed with galvo delivery
Laser average CW power – 8W, 12W and 20W
Min. spot size – <20µm (8W, 100mm lens)
Pulse energy at 5kHz – 0.5mJ
Peak power at 5kHz – >8kW
Pulse duration at 5kHz – 60ns
Peak to peak stability, pulsed – <3%
Beam quality pulsed – 20W: <5.5mm.mrad (M² = 4)
 12W: <3.5mm.mrad (M² = 2.5)
 8W: <1.1mm.mrad (M² = 1.6)

Control electronics – 19 inch rack mounted module

utilities

input voltage single phase + Earth, 50 or 60 Hz;
110, 180, 208, 220, 240

power requirement 1 kW



software

Electrox laser marking software has been developed in conjunction with Cobra V12/20 to ensure optimum marking performance.

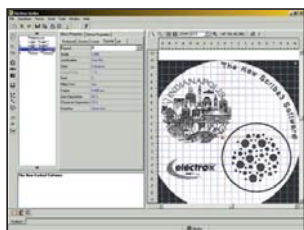

- Fast file transfer to the laser
- File import formats: PLT (HPGL), AI, DXF, PNL (Electrox), BMP, TIFF
- Bar Codes
- Two Dimensional Codes including Data Matrix
- Automatic Serialization
- File Input Programming (Mail Merge)
- Date Coding
- Fill Editor
- Motion Control (4 Axis)
- Multiple I/O Interface



USA Office

5601 Fortune Circle, South Drive, Suite A,
Indianapolis, IN 46241, USA.
Tel: +1 317 248 2632 Fax: +1 317 240 5787
e-mail: sales.us@electrox.com

UK Office

Avenue One, The Business Park,
Letchworth Garden City, Hertfordshire, SG6 2HB, UK.
Tel: +44 (0)1462 472400 Fax: +44 (0)1462 472444
e-mail: sales.uk@electrox.com

Asia Pacific Office

Level 27, Prudential Tower, 30 Cecil Street
Singapore 049712
Tel: (65) 6725 6223 Fax: (65) 6725 6224

Electrox Razor, Scorpion, Raptor, Scorpion Rapide, E-Box, MaxBox, EF Technology, Scriba and Cobra are registered trademarks of 600 UK Limited. Electrox has a policy of continuous product development and improvement and reserves the right to modify designs and specifications without notice.